

Produkt Datenblatt

Gerätebezeichnung: Multi Kanalgerät RAS-M10U2DVG-E

Technische Daten

	Einheiten	Werte
Nennkühlleistung	kW	2,7
Nennheizleistung	kW	4,0
Luftvolumenstrom (h/n) C	m ³ /h	570 - 380
Schalldruckpegel (h/n) C	dB (A)	36 / 25
Luftvolumenstrom (h/n) H	m ³ /h	570 - 380
Schalldruckpegel (h/n) H	dB (A)	36 / 25
Abmessungen (HxBxT)	mm	210 x 700 x 450
Gewicht	kg	16
Bördelanschlüsse - Einspritz	mm	1/4"
Bördelanschlüsse - Gas	mm	3/8"
Pressung	Pa	10 - 45
Kondensatanschluss	DN	25

Abbildung:



Maßskizze:

4. CONSTRUCTION VIEWS

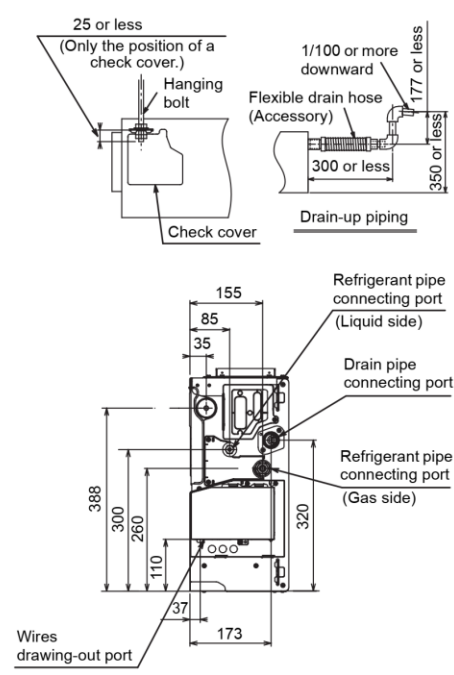
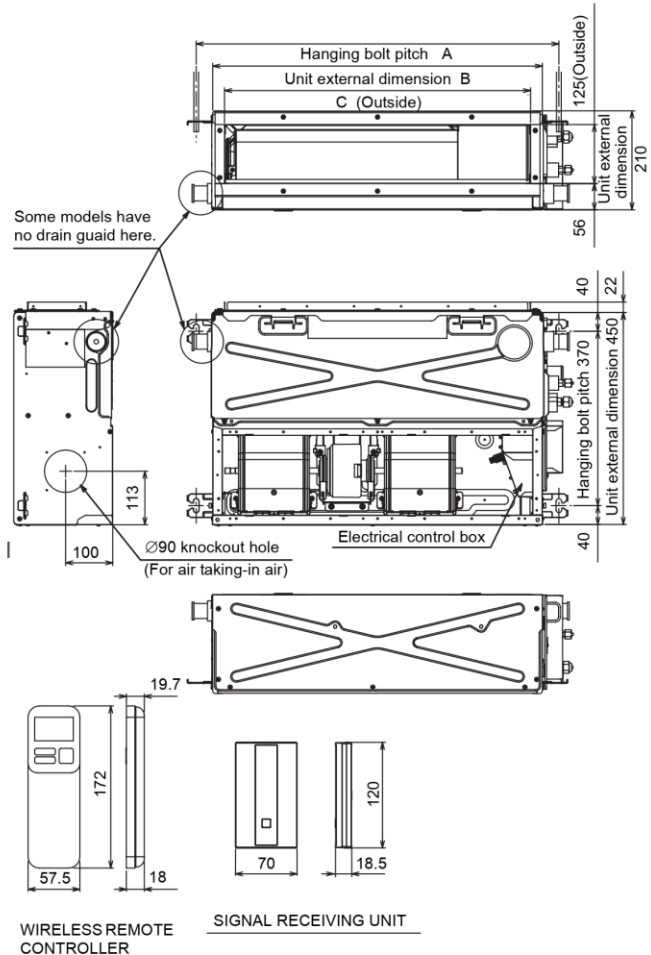

	A	B	C
07,13 type	770	700	650
16 type	970	900	850
22,24 type	1,170	1,100	1,050